

SOLAR LIGHT



APPLICATION



SCHEMATIC

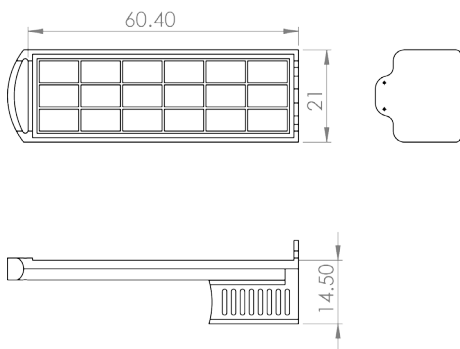

BENEFITS

- ✓ Integrated all in one, standardized protection, easy installation
- ✓ Apply high efficiency lithium ion battery, long life and better performance to guarantee the whole products service life
- ✓ Use Cree LED, 50,000 hrs life time
- ✓ Alloy material for the main body corrosion prevention and rust protection
- ✓ Water resistance structure, safe and reliable

FEATURES



Energy saving



Long life
(8-10 years)



Water resistance
structure



Alloy material
for corrosion prevention
the main body



Intelligent power
control

SPECIFICATION

MODEL	FA-LI-5V-25W	FA-LI-5V-15W
Lamp power	25W	15W
Input Voltage	DC 5V	
Led chip	Cree LED	
Luminous flux	3500lumen	2100Lumen
Lamp efficiency	>140lm/watt	>84lm/watt
power factor	95%	
Temperature	-20C to 70C	
Working humidity	10%-90% RH	
Service life	50,000hr	
system Resistance (Rja)	0.1C/W	
Junction Temperature	45C	
Protection	IP65	
Lamp fixture	High-pressure die-casting aluminum. Corrosion resistant	



Outstanding low-light performance



High PTC rating of up to 91.55%



Junction box for long term weather endurance



Heavy snow load



Cell efficiency of up to 20.0%



Excellent module efficiency